

## Installation Check List For Your Machine

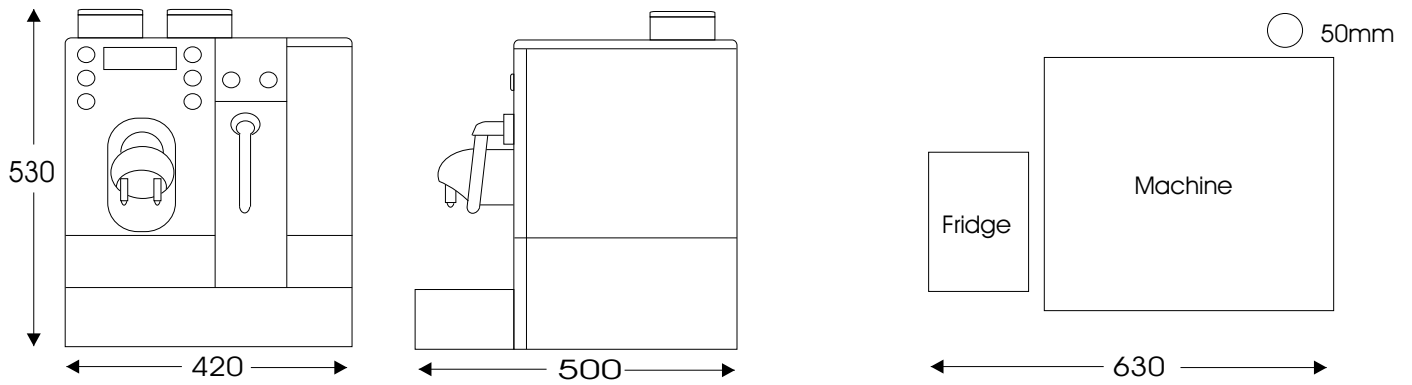

Model	Group Height	Water Tank	Voltage	Wattage	Amps	Weight
C7	75mm-155mm	5lt	220V	2200W	10.5A	18Kg

Please Check All Boxes

- |   |                          |  |                          |
|---|--------------------------|--|--------------------------|
| Electrical supply socket within 1 metre which is working. | <input type="checkbox"/> | Is work top less then 900mm in height          | <input type="checkbox"/> |
| Access to the bean hoppers, (no shelves above etc)        | <input type="checkbox"/> | All construction work in the area is complete? | <input type="checkbox"/> |
| Work top area complete and with space for machine         | <input type="checkbox"/> | All construction work in the area is complete? | <input type="checkbox"/> |

If the machine is to be connected to the mains water

- |   |                          |  |                          |
|---|--------------------------|--|--------------------------|
| Water supply is on and working?   | <input type="checkbox"/> | Space for water filter under work top                        | <input type="checkbox"/> |
| 15 mm Dedicated cold water supply within 1 metre with 3/4" washer valve | <input type="checkbox"/> | Has 50mm diameter hole been made through work top for pipes. | <input type="checkbox"/> |