

## Installation Check List For Your Machine

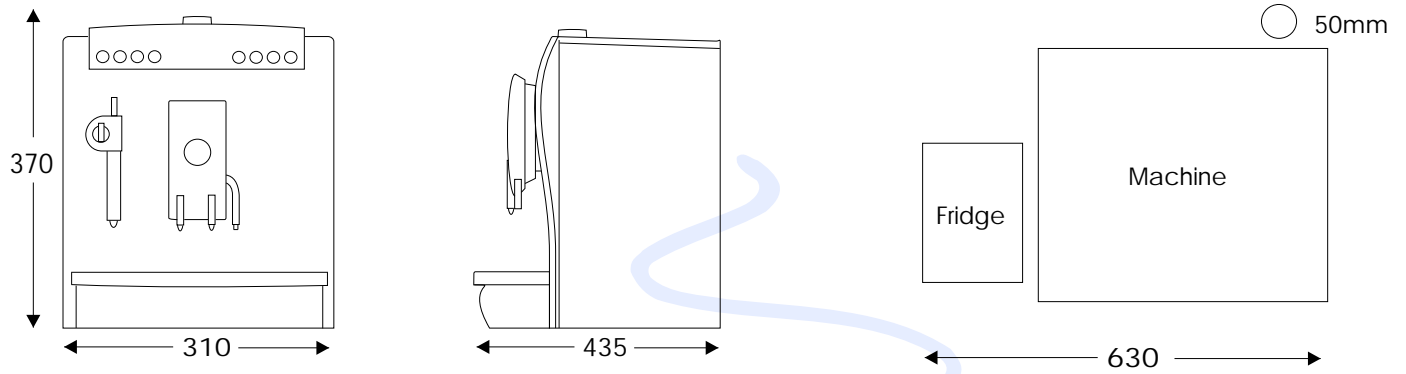

Model	Group Height	Water Tank	Voltage	Wattage	Amps	Weight
C5	65mm-102mm	2.8lt	220V	1350W	6.0A	13.3Kg

Please Check All Boxes

- |   |                          |  |                          |
|---|--------------------------|--|--------------------------|
| Electrical supply socket within 1 metre                                 | <input type="checkbox"/> | Is work top less than 900mm in height                                  | <input type="checkbox"/> |
| 15 mm Dedicated cold water supply within 1 metre with 3/4" washer valve | <input type="checkbox"/> | Has 50mm diameter hole been made through work top for pipes if plumbed | <input type="checkbox"/> |
| Access to the bean hoppers, (no shelves above etc)                      | <input type="checkbox"/> | Space for water filter under work top if the machine is plumbed in?    | <input type="checkbox"/> |
| Work top area complete and with space for machine                       | <input type="checkbox"/> | All construction work in the area is complete?                         | <input type="checkbox"/> |
| The electrical and water supplies are working?                          | <input type="checkbox"/> |  |                          |